

Circuito do sensor de fluxo de ar (VAF) para UCE's analógicas

GM	- Kadet 2.0 GSi. - Monza Classic MPFI, Monza 500 EF
FIAT	- Elba TOP, Uno MPI
VW e FORD	- 1988 a 1994

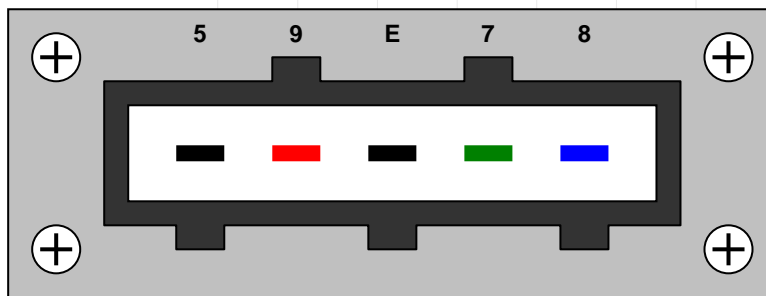
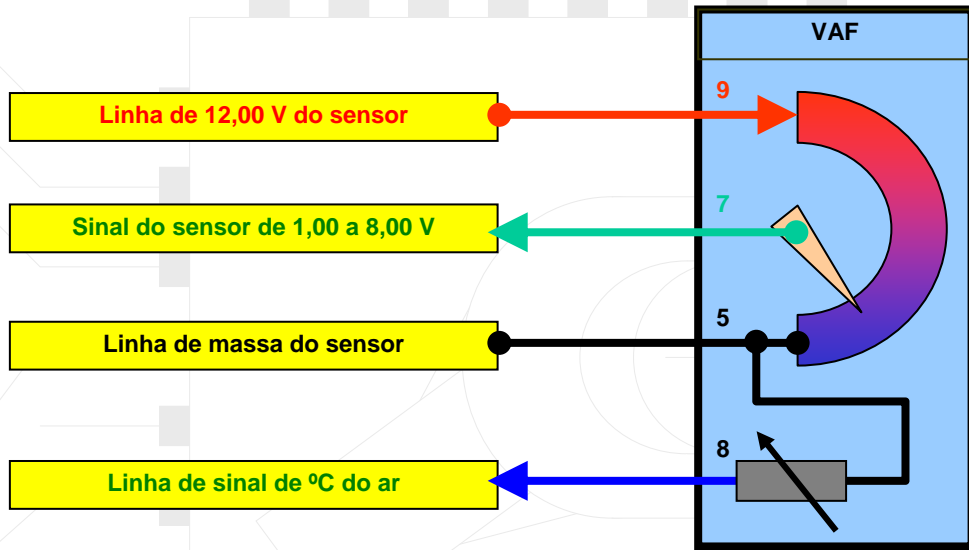

**Circuito do sensor de fluxo de ar (VAF) para UCE's digitais**

GM	- Omega e Suprema 2.0, 3.0. - Vectra GLS e CD até 97
FIAT	- Tempra Turbo e Stile (no Tempra, este pino é o 1)
Alfa Romeo	- 164 3.0 12V, 24V e Spider 24V

